

Lenticular ring joint gaskets for flanged joints

DIN
2696

ICS 23.040.80

Supersedes
April 1972 edition.

Flanschverbindungen mit Dichtlinse

In keeping with current practice in standards published by the International Organization for Standardization (ISO), a comma has been used throughout as the decimal marker.

Foreword

This standard has been prepared by Technical Committee *Flansche und ihre Verbindungen* of the *Normenausschuss Rohre, Rohrverbindungen und Rohrleitungen* (Pipes and Pipe Joints Standards Committee).

Amendments

This standard differs from the April 1972 edition as follows:

- a) The standard now only covers nominal sizes up to DN 200.
- b) For each PN designation (except for PN 400), two dimension series per nominal size have been specified.
- c) Technical delivery conditions have been specified.
- d) Appendices A and B have been included.

Previous edition

DIN 2696: 1972-04.

All dimensions are in millimetres

1 Scope

This standard applies to lenticular ring joint gaskets for flanged joints in piping systems operating at pressures exceeding 63 bar. It specifies dimensions and the design of DN 10 to DN 200 gaskets rated for pressures from 63 bar to 400 bar.

2 Normative references

This standard incorporates, by dated or undated reference, provisions from other publications. These *normative references* are cited at the appropriate places in the text, and the titles of the publications are listed below. For dated references, subsequent amendments to or revisions of any of these publications apply to this standard only when incorporated in it by amendment or revision. For undated references, the latest edition of the publication referred to applies.

DIN 2627 PN 400 welding neck flanges

DIN 2628 PN 250 welding neck flanges

Continued on pages 2 to 12.

Translation by DIN-Sprachendienst.

In case of doubt, the German-language original should be consulted as the authoritative text.

DIN 2629	PN 320 welding neck flanges
DIN 2636	PN 64 welding neck flanges
DIN 2637	PN 100 welding neck flanges
DIN 2638	PN 160 welding neck flanges
DIN EN 1092-1	Circular flanges for pipes, valves, fittings and accessories, PN designated – Part 1: Steel flanges ¹⁾
DIN EN 1591	Flanges and their joints – Design rules for gasketed circular flange connections ¹⁾
DIN EN 10088-1	Stainless steels – Part 1: List of stainless steels
DIN EN 10204	Inspection documents for metallic products (includes Amendment A1 : 1995)
DIN EN 10222-2	Steel forgings for pressure purposes – Part 2: Ferritic and martensitic steels with specified elevated temperature properties (includes Corrigendum AC : 2000)

AD-Merkblatt (AD Code of practice) B7 *Schrauben* (Screws and bolts)²⁾
AD-Merkblatt (AD Code of practice) B8 *Flansche* (Flanges)²⁾

3 Concepts and symbols

3.1 Concepts

3.1.1 Lenticular ring joint gasket

Lens-shaped sealing element for use in flanged joints.

3.1.2 Flanged joint assembly

Joint assembly consisting of two flanges, tightening bolts and a gasket.

3.1.3 Gasket width

Effective width resulting from the plastic deformation of the gasket's contact faces that occurs during assembly; designated by b_D (cf. detail X in figure 1).

For gaskets made of iron, b_D is given by equation (1):

$$b_D = 0,58 \times \sqrt[3,5]{r \left(\frac{F_{DN}}{d_D \times \pi \times R_m} \right)^{2,5}} \quad (1)$$

where

F_{DN} (equal to $F_D/\sin 70^\circ$) is the normal component of the gasket force;

r is the radius, in mm;

R_m is the tensile strength of the gasket material.

NOTE: DIN EN 1591 enables the gasket width to be determined both approximately and exactly on the basis of the maximum permissible compressive stress, Q_{max} , rather than the tensile strength of the gasket material, R_m .

In the case of gas piping systems, *AD-Merkblätter* B7 and B8 specify a gasket design based on an assumed constant width, k_D , of 2 mm or, k_r , of 6 mm [2], [3]. Since the results obtained in such calculations may deviate considerably from the actual dimensions, it is recommended that equation (1) be used for flange design calculations. Because the force F_{DN} is itself a function of the gasket width, b_D , this value can only be determined iteratively.

3.1.4 Gasket diameter

Diameter lying approximately halfway between diameters d_i and d_s , as given by equation (2):

$$d_D \approx (d_i + d_s)/2 \quad (2)$$

Designated by d_D (cf. Appendix A).

¹⁾ Currently at draft stage.

²⁾ Obtainable from *Beuth Verlag GmbH*, 10772 Berlin, Germany.

3.2 Symbols, quantities and units

Table 1: Symbols, quantities and units

Symbol	Quantity
d_1	Inside diameter of flange or flange facing, in mm
d_D	Gasket diameter, in mm
d	Inside diameter of gasket, in mm
d_2	Outside diameter of gasket, in mm
d_3	Outside diameter of flange or flange facing, in mm
$h_1^{1)}$	Gasket height at d_1 , in mm
h_D	Gasket height at d_D , in mm
$h_2^{1)}$	Gasket height at d_2 , in mm
x	Distance between raised faces, in mm
b_D	Gasket width, in mm
r	Radius, in mm
R_m	Tensile strength, in N/mm ²
F_D	Gasket force, in N
F_{DN}	Normal component of gasket force, in N
F_{DR}	Radial component of gasket force, in N

¹⁾ Reductions in height due to rounded edges or chamfers may be ignored.

4 Designation

Designation of a DN 50 lenticular ring joint gasket of dimension series 1 for a PN 160 flange, made of grade P245GH steel:

Gasket DIN 2696 – Series 1 – DN 50 – PN 160 – P245GH

5 Requirements

5.1 Design of facings

Gaskets shall be used with weld-neck flanges of the same nominal pressure rating as the gasket and complying with DIN EN 1092-1, DIN 2627, DIN 2628, DIN 2629 or DIN 2638, use of other flanges of equivalent design being permitted.

Flange facings shall be tapered so that they form an included angle of 140° when flanges are assembled.

The gasket facings shall be spherical. See Explanatory notes for other designs.

The surface roughness parameter R_z of facings shall be 6,3 µm in the radial direction. Surfaces shall be free of cracks and scratches.

5.2 Dimensions

The dimensions of gaskets shall be as specified in figure 1 and tables 2 to 12.

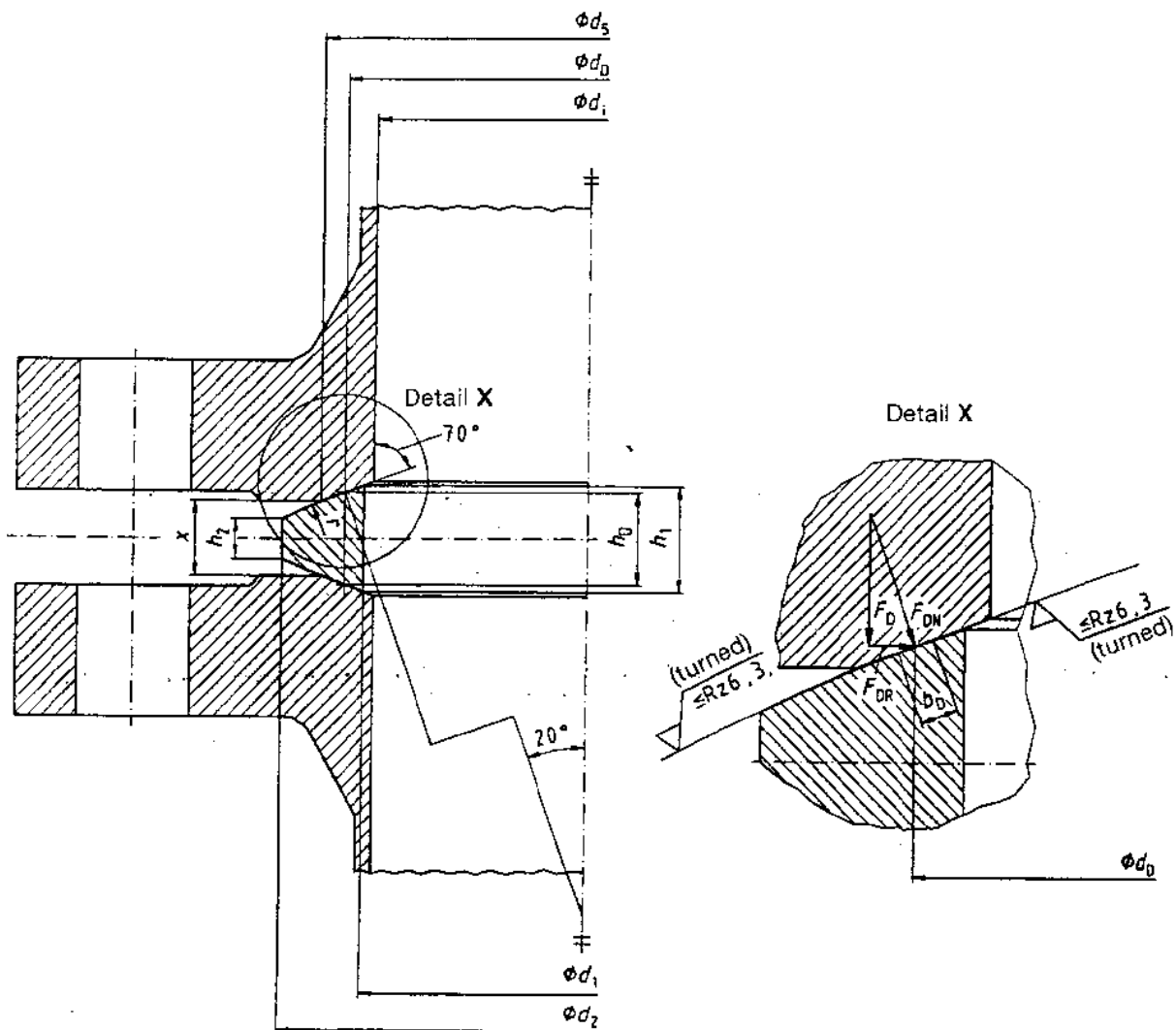

Figure 1: Gasket dimensions (notation)

Table 2: Dimensions of series 1 gaskets for PN 63 flanges as in DIN 1092-1

DN	h_D	r	d_D	d_5	x	d_1	h_1	d_2	h_2
10	-	-	-	-	-	-	-	-	-
15	-	-	-	-	-	-	-	-	-
25	-	-	-	-	-	-	-	-	-
40	-	-	-	-	-	-	-	-	-
50	11,3	90,0	61,6	68,0	9,0	55,0	13,6	78,0	4,4
65	15,8	113,0	77,3	85,0	13,0	70,0	18,3	102,0	5,1
80	15,7	131,0	89,6	97,0	13,0	82,0	18,3	116,0	4,4
100	18,7	171,0	117,0	127,0	15,0	107,0	22,1	143,0	7,9
125	26,9	210,0	143,6	157,0	22,0	131,0	31,2	180,0	11,7
150	30,6	249,0	170,3	183,0	26,0	158,0	34,9	210,0	14,2
200	34,0	327,0	223,7	243,0	27,0	205,0	40,5	276,0	12,4

Table 3: Dimensions of series 2 gaskets for PN 64 flanges as in DIN 2636

DN	h_D	r	d_D	d_5	x	d_1	h_1	d_2	h_2
10	-	-	-	-	-	-	-	-	-
15	-	-	-	-	-	-	-	-	-
25	-	-	-	-	-	-	-	-	-
40	-	-	-	-	-	-	-	-	-
50	12,1	87,0	59,5	68,0	9,0	52,0	14,6	78,0	4,1
65	-	-	-	-	-	-	-	-	-
80	-	-	-	-	-	-	-	-	-
100	19,9	166,0	113,6	127,0	15,0	100,0	24,5	143,0	7,5
125	28,1	205,0	140,2	157,0	22,0	124,0	33,6	180,0	11,2
150	32,4	242,0	165,5	183,0	26,0	148,0	38,4	210,0	13,6
200	-	-	-	-	-	-	-	-	-

Table 4: Dimensions of series 1 gaskets for PN 100 flanges as in DIN EN 1092-1

DN	h_D	r	d_D	d_5	x	d_1	h_1	d_2	h_2
10	6,8	23,0	15,7	18,0	6,0	14,0	7,4	21,0	4,5
15	7,9	32,0	21,9	27,0	6,0	18,0	9,1	28,0	5,3
25	8,0	49,0	33,5	39,0	6,0	29,0	9,5	43,0	4,0
40	10,3	71,0	48,6	55,0	8,0	43,0	12,2	62,0	4,7
50	11,6	89,0	60,9	68,0	9,0	54,0	13,9	78,0	4,3
65	16,1	112,0	76,6	85,0	13,0	69,0	18,7	102,0	5,0
80	15,9	130,0	88,9	97,0	13,0	81,0	18,7	116,0	4,3
100	19,1	169,0	115,6	127,0	15,0	105,0	22,8	143,0	7,8
125	27,4	208,0	142,3	157,0	22,0	128,0	32,3	180,0	11,5
150	31,4	246,0	168,3	183,0	26,0	155,0	36,0	210,0	14,0
200	35,0	323,0	220,9	243,0	27,0	200,0	42,2	276,0	12,1

Table 7: Dimensions of series 2 gaskets for PN 160 flanges as in DIN 2638

DN	h_D	r	d_D	d_5	x	d_1	h_1	d_2	h_2
10	7,6	20,0	13,7	18,0	6,0	10,0	8,7	21,0	4,0
15	8,1	31,0	21,2	27,0	6,0	16,0	9,7	28,0	5,2
25	8,7	46,0	31,5	39,0	6,0	25,0	10,8	43,0	3,6
40	11,3	67,0	45,8	55,0	8,0	38,0	13,9	62,0	4,2
50	12,3	86,0	58,8	68,0	9,0	49,0	15,6	78,0	4,0
65	-	-	-	-	-	-	-	-	-
80	-	-	-	-	-	-	-	-	-
100	21,4	160,0	109,4	127,0	15,0	92,0	27,2	143,0	7,0
125	30,1	197,0	134,8	157,0	22,0	113,0	37,3	180,0	10,3
150	34,8	232,0	158,7	183,0	26,0	134,0	43,1	210,0	12,6
175	-	-	-	-	-	-	-	-	-
200	-	-	-	-	-	-	-	-	-

Table 8: Dimensions of series 1 gaskets for PN 250 flanges as in DIN 2628

DN	h_D	r	d_D	d_5	x	d_1	h_1	d_2	h_2
10	-	-	-	-	-	-	-	-	-
15	7,9	32,0	21,9	27,0	6,0	17,0	9,4	28,0	5,3
25	8,2	48,0	32,8	39,0	6,0	27,0	10,2	43,0	3,9
40	11,1	68,0	46,5	55,0	8,0	39,0	13,6	62,0	4,3
50	12,6	85,0	58,1	68,0	9,0	48,0	15,9	78,0	3,9
65	17,5	106,0	72,5	85,0	13,0	61,0	21,4	102,0	4,2
80	16,2	129,0	88,2	97,0	13,0	80,0	19,0	116,0	4,2
100	20,1	165,0	112,9	127,0	15,0	99,0	24,8	143,0	7,5
125	28,6	203,0	138,9	157,0	22,0	121,0	34,6	180,0	11,0
150	33,4	238,0	162,8	183,0	26,0	143,0	40,1	210,0	13,2
175	-	-	-	-	-	-	-	-	-
200	33,8	320,0	218,9	243,0	25,0	195,0	41,9	276,0	9,8

Table 9: Dimensions of series 2 gaskets for PN 250 flanges as in DIN 2628

DN	h_D	r	d_D	d_5	x	d_1	h_1	d_2	h_2
10	-	-	-	-	-	-	-	-	-
15	8,1	31,0	21,2	27,0	6,0	15,0	10,0	28,0	5,2
25	9,0	45,0	30,8	39,0	6,0	23,0	11,4	43,0	3,5
40	11,8	65,0	44,5	55,0	8,0	35,0	14,9	62,0	3,9
50	13,3	82,0	56,1	68,0	9,0	45,0	16,9	78,0	3,5
65	-	-	-	-	-	-	-	-	-
80	-	-	-	-	-	-	-	-	-
100	-	-	-	-	-	-	-	-	-
125	-	-	-	-	-	-	-	-	-
150	-	-	-	-	-	-	-	-	-
175	-	-	-	-	-	-	-	-	-
200	-	-	-	-	-	-	-	-	-

Table 10: Dimensions of series 1 gaskets for PN 320 flanges as in DIN 2629

DN	h_D	r	d_D	d_5	x	d_1	h_1	d_2	h_2
10	7,1	22,0	15,0	18,0	6,0	12,0	8,1	21,0	4,4
15	8,1	31,0	21,2	27,0	6,0	15,0	10,0	28,0	5,2
25	8,7	46,0	31,5	39,0	6,0	24,0	11,1	43,0	3,6
40	11,6	66,0	45,1	55,0	8,0	36,0	14,5	62,0	4,1
50	12,8	84,0	57,5	68,0	9,0	48,0	16,0	78,0	3,8
65	16,3	111,0	75,9	85,0	13,0	67,0	19,3	102,0	4,9
80	16,7	127,0	86,9	97,0	13,0	77,0	20,1	116,0	4,0
100	-	-	-	-	-	-	-	-	-
125	27,1	209,0	143,0	157,0	22,0	129,0	31,9	180,0	11,6
150	33,1	239,0	163,5	183,0	26,0	144,0	39,7	210,0	13,3
175	30,9	279,0	190,8	218,0	21,0	164,0	39,9	243,0	8,8
200	35,8	312,0	213,4	243,0	25,0	185,0	45,3	276,0	9,0

Table 11: Dimensions of series 2 gaskets for PN 320 flanges as in DIN 2629

DN	h_D	r	d_D	d_5	x	d_1	h_1	d_2	h_2
10	7,6	20,0	13,7	18,0	6,0	9,0	9,0	21,0	4,0
15	8,4	30,0	20,5	27,0	6,0	14,0	10,3	28,0	5,0
25	9,5	43,0	29,4	39,0	6,0	20,0	12,3	43,0	3,2
40	12,1	64,0	43,8	55,0	8,0	32,0	15,7	62,0	3,8
50	-	-	-	-	-	-	-	-	-
65	-	-	-	-	-	-	-	-	-
80	-	-	-	-	-	-	-	-	-
100	19,6	167,0	114,2	127,0	15,0	101,0	24,2	143,0	7,6
125	28,9	202,0	138,2	157,0	22,0	119,0	35,3	180,0	10,9
150	-	-	-	-	-	-	-	-	-
175	-	-	-	-	-	-	-	-	-
200	-	-	-	-	-	-	-	-	-

Table 12: Dimensions of series 1 gaskets for PN 400 flanges as in DIN 2627

DN	h_D	r	d_D	d_5	x	d_1	h_1	d_2	h_2
10	7,6	20,0	13,7	18,0	6,0	10,0	8,7	21,0	4,0
15	7,9	32,0	21,9	27,0	6,0	17,0	9,4	28,0	5,3
25	8,0	49,0	33,5	39,0	6,0	29,0	9,5	43,0	4,0
40	10,6	70,0	47,9	55,0	8,0	41,0	12,9	62,0	4,6
50	12,1	87,0	59,5	68,0	9,0	52,0	14,6	78,0	4,1
65	15,8	113,0	77,3	85,0	13,0	70,0	18,3	102,0	5,1
80	16,2	129,0	88,2	97,0	13,0	80,0	19,0	116,0	4,2
100	20,9	162,0	110,8	127,0	15,0	96,0	25,9	143,0	7,2
125	26,4	212,0	145,0	157,0	22,0	134,0	30,2	180,0	11,8
150	32,1	243,0	166,2	183,0	26,0	150,0	37,7	210,0	13,7
175	-	-	-	-	-	-	-	-	-
200	34,0	319,0	218,2	243,0	25,0	193,0	42,6	276,0	9,7

There is no dimension series 2 for PN 400 flanges.

5.3 Materials

Table 13 lists typical materials used for gaskets.

Table 13: Gasket materials ¹⁾

Designation	Material number	As in
P245GH	-	EN 10222-2
X6CrNiMoTi17-12-2	1.4571	DIN EN 10088-1
X6CrNiTi18-10	1.4541	DIN EN 10088-1
¹⁾ Use of other materials is subject to agreement.		

NOTE: To obtain a greater deformability of gasket facings, gasket materials should have a hardness value lower than that of the flange material. This cannot be ensured when gaskets and flanges are made from the same material, but experience has shown that even in this case the plastic deformation of the gasket is considerably greater than that of the facing.

5.4 As-delivered condition

Gaskets shall have the dimensions specified in this standard and meet the requirements specified in the relevant material standards. Proof of compliance with the requirements for yield strength, tensile strength and elongation at break shall be furnished by submitting an inspection certificate 3.1 B as in DIN EN 10204.

Gaskets shall be packed so as to prevent any mechanical damage or corrosion of facings during transport.

5.5 Marking

Gaskets complying with this standard shall be marked with the following information:

- a) manufacturer's mark;
- b) series designation;
- c) nominal size;
- d) PN designation;
- e) material.

EXAMPLE:

XXXX/1/DN 50/PN 160/P245GH

Appendix A

Explanatory notes

A.1 General

This standard was revised to improve gasket performance and ensure interchangeability with the gaskets used in existing systems. The gasket diameter has been changed to ensure a better fit with existing flange facings. Flange facing dimensions and dimension x have not been changed, meaning that gaskets complying with this standard are interchangeable with those complying with the previous edition.

Since the permissible operating temperatures for gaskets depend on their material and the other service conditions, analysis by calculation is to be carried out on a case-by-case basis, considering at least the following cases:

- a) resistance to internal pressure, taking into account the radial component of the gasket force, where necessary;
- b) resistance to the radial component of the gasket force at elevated temperature, disregarding loading due to internal pressure.

A.2 Gasket design

In addition to the gasket designs specified in this standard, a further design with spherical facing is found in process engineering (designated as the IG system). Further information will be provided in the relevant works standards.

The sealing system described in this standard (where spherical gasket faces are seated on conical flange facings) permits compensation for slight eccentricities of pipe axes, this effect being lessened by bolt flexure (increased basic stress) and differences in bolt/hole diameters.

A.3 Other gasket forms

In particular applications, the calculated spherical radius of gasket faces is smaller than that specified in this standard. Gaskets manufactured on the basis of these calculations seal by means of toroidal zones. Therefore, only slight eccentricities of pipe axes are acceptable. Experience has shown, however, that these have no adverse effect in practice.

Annex B

Calculation of gasket dimensions

B.1 The values of d_2 , d_5 and x are the same as those given in the April 1972 edition of this standard.

B.2 Determining radius r

$$d'_D = (d_i + d_5)/2 \quad (\text{B.1})$$

$$r' = \frac{d'_D}{2 \times \cos 70^\circ} \quad (\text{B.2})$$

The radius r is obtained by rounding the value for r' to the nearest integer.

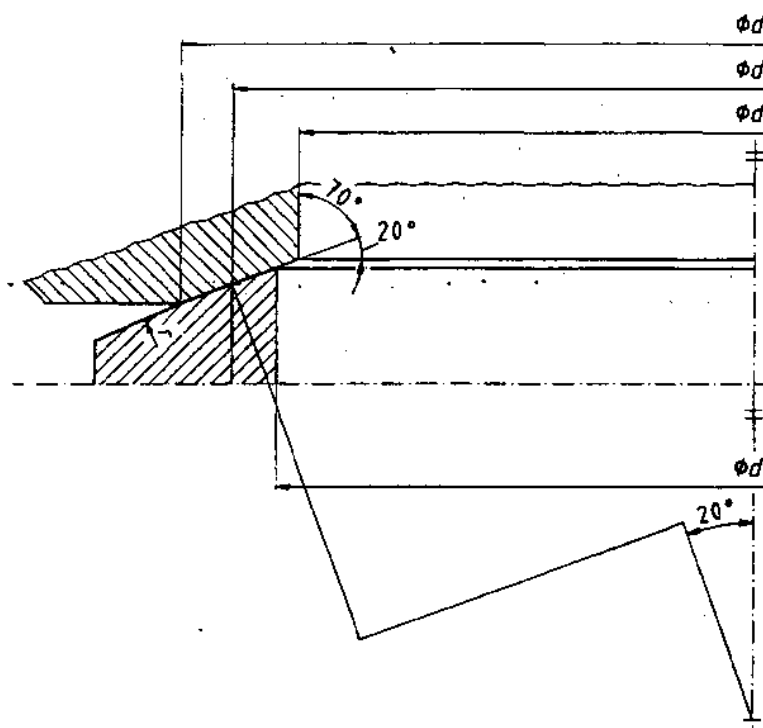

Figure B.1: Radius r

B.3 Determining d_D

$$d_D = 2 \times r \times \cos 70^\circ \quad (\text{B.3})$$

B.4 Determining h_D

$$h_D = x + \frac{(d_5 - d_D)}{\tan 70^\circ} \quad (\text{B.4})$$

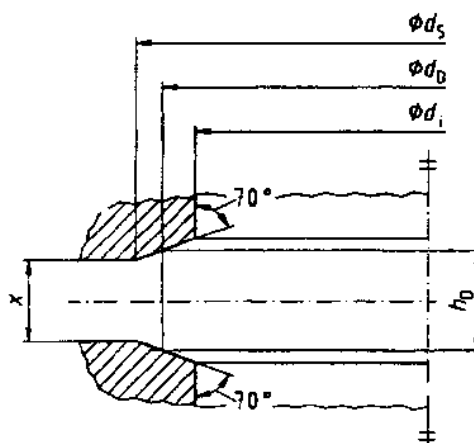

Figure B.2: Dimension h_D

B.5 Determining d_1

d_1 is given by rounding the flange diameter d_1 to the nearest integer.

B.6 Determining h_1 and h_2

$$h_1 = h_D + 2 \times h_b - 2 \times h_a \quad (\text{B.5})$$

$$h_2 = h_D + 2 \times h_b - 2 \times h_c \quad (\text{B.6})$$

$$h_a = r - \frac{1}{2} \times \sqrt{4 \times r^2 - d_1^2} \quad (\text{B.7})$$

$$h_b = r - \frac{1}{2} \times \sqrt{4 \times r^2 - d_D^2} \quad (\text{B.8})$$

$$h_c = r - \frac{1}{2} \times \sqrt{4 \times r^2 - d_2^2} \quad (\text{B.9})$$

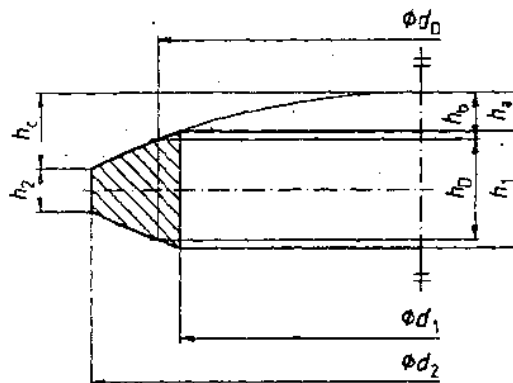

Figure B.3: Dimensions h_1 and h_2

Bibliography

- [1] Tückmantel, H.-J., *Die Berechnung der Dichtflächenbreite metallischer Schmiegedichtungen* (Calculating the width of metallic gaskets), *3R-international* 35, 1996: 8, pp. 501–504